

Powdered Autofill Ultra Gourmet Ice® System with 2 Hoppers



ULTRA-2 PAF

Dimensions:
42"H x 16"W x 25"D
(106.7cm H x 40.6cm W x 63.5cm D)

Features

Ultra Gourmet Ice® System

- Powdered autofill product hoppers refill product at a rate of 1.1 fluid oz. (32.5 mL)/sec.
- Patented reversing auger design quickens freeze time and reduces air mixing with product.
- Very simple to program and run with touchpad display, which also guides cleaning and preventive maintenance.
- Enhanced “no-lube” design on faucets and seals which simplifies installation and cleaning.
- Refrigeration system internally monitored to ensure long lasting performance.
- Two large 2 gallon (7.57 litre) hoppers for optimum cooling & serving capacity.
- Lighted for merchant displays.
- Full 3-year parts and labor warranty on electronics and 5-year parts warranty on compressor. See the product manual for additional details.

For current specification sheets and other information, go to www.bunn.com.

International models may vary in appearance.

Related Products

Conversion Kit

Kit converts hoppers on CDS-2 PAF machine to new ULTRA-2 PAF style hopper/faucet.

CDS-2 PAF Hopper Kit

Product No.: 28485.0046



Plastic hoppers pull out easily to refill powdered product.

Dimensions & Specifications

Model	Product #	Volts	Amps	Capacity	Shipping Weight	Cord Attached	Agency
ULTRA-2 PAFA (All Black)	34000.0006	230	15	5 lbs. dry product (2.27 kg dry product)	177.6 lbs. (80.6 kg)	Yes	CE
ULTRA-2 PAFA (White/Stainless)	34000.0007	230	15	5 lbs. dry product (2.27 kg dry product)	175.2 lbs. (79.5 kg)	Yes	CE

Electrical: Model requires 2-wires plus ground service rated 220-240V, single phase, 50/60 Hz.

Plumbing: 20-90 psi (138-621 kPa). Machine supplied with 1/4" male flare fitting.

Note: One should not use electrical extension cord to operate this machine. A dedicated circuit is recommended.

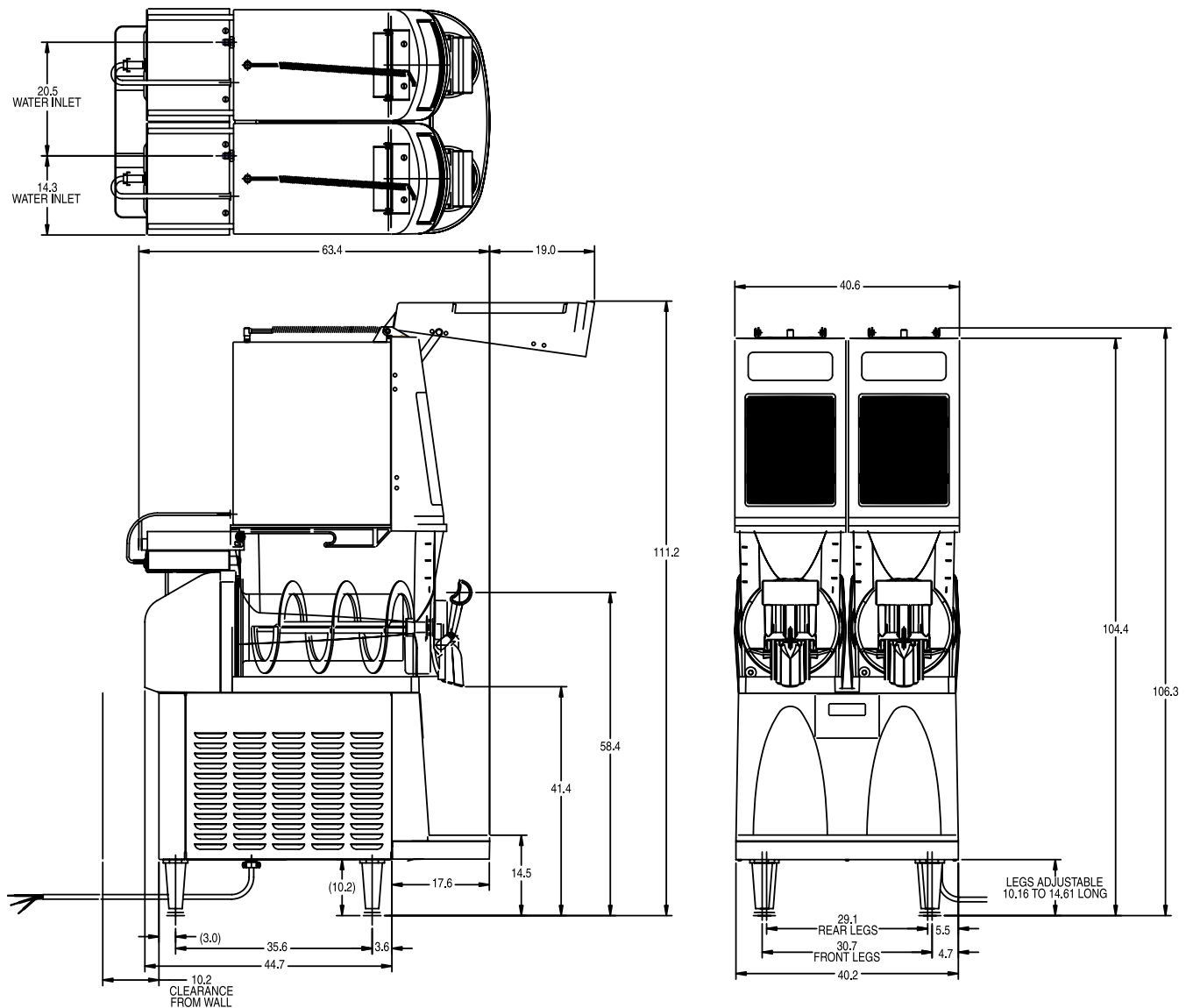

Bunn-O-Matic® Corporation - 1400 Stevenson Drive Springfield, Illinois 62703 • USA • +1-217-529-6601 • Fax +1-217-529-2827 • www.bunn.com

BUNN® practices continuous product research and improvement. We reserve the right to change specifications and product design without notice. Such revisions do not entitle the buyer to corresponding changes, improvements, additions or replacements for previously purchased equipment.

All dimensions shown in centimeters. Bunn-O-Matic Corporation owns all copyrights relating to materials in this publication. Please contact BUNN to request permission to reproduce any portion of this publication.