

2 Hopper Ultra Gourmet Ice[®] System



Ultra-2

Dimensions:
31.9"H x 16"W x 24.5"D
(81 cm H x 40.6 cm W x 62.2 cm D)

Features

Ultra Gourmet Ice[®] System

- Patented reversing auger design quickens freeze time and reduces air mixing with product.
- Very simple to program and run with touchpad display, which also guides cleaning and preventive maintenance.
- Enhanced “no-lube” design on faucets and seals which simplifies installation and cleaning.
- Refrigeration system internally monitored to ensure long lasting performance.
- Two large 3-gallon (11.4 litre) hoppers for optimum cooling & serving capacity.
- AFI models include autofill hoppers and factory installed Liquid Autofill (LAF) kit for use with third party brix pumps.
- Lighted displays for merchant graphics.
- Full 2-year parts and 1-year labor warranty. 5-year parts and 1-year labor warranty on compressor and 3-year parts and labor warranty on electronics. See the product manual for additional details.
- Preventive maintenance kit: 34245.0000. 

For current specification sheets and other information, go to www.bunn.com.

International models may vary in appearance.

Related Products



Kit for Ultra-2 Lid Lock

Part Number: 34996.0000 (white)

Kit for Ultra-2 Lid Lock and Handles

Part Number: 34996.0002 (white)

Kit for Ultra-2 Handle Lock

Part Number: 34996.0004 (white & black)

Kit for Ultra-2 Lid Lock Kit

Part Number: 34996.0001 (black)

Kit for Ultra-2 Lid Lock and Handles

Part Number: 34996.0003 (black)

Dimensions & Specifications

Model	Product #	Volts	Amps	Capacity	Shipping Weight	Cord Attached	Agency
ULTRA-2A (All Black)	34000.0002	230	6.5	2 Hoppers@3.0 gal each (2 Hoppers @ 11.4L)	136.6 lbs. (62 kg)	Yes	CE
ULTRA-2A (White/Stainless)	34000.0003	230	6.5	2 Hoppers@3.0 gal each (2 Hoppers @ 11.4L)	136.9 lbs. (62.1 kg)	Yes	CE
ULTRA-2A (White/Stainless)†	34000.0065	230	6.5	2 Hoppers@3.0 gal each (2 Hoppers @ 11.4L)	136.9 lbs. (62.1 kg)	Yes	CE
ULTRA-2A (Black/Stainless)†	34000.0066	230	6.5	2 Hoppers@3.0 gal each (2 Hoppers @ 11.4L)	136.9 lbs. (62.1 kg)	Yes	CE
ULTRA-2 (White/Stainless) (Spanish)	34000.0063	120	12	2 Hoppers@3.0 gal each (2 Hoppers @ 11.4L)	136.9 lbs. (62.1 kg)	Yes	NSF ETL
ULTRA-2A (White/Stainless) (painted frame)	34000.0071	230	12	2 Hoppers@3.0 gal each (2 Hoppers @ 11.4L)	136.9 lbs. (62.1 kg)	Yes	CE
ULTRA-2 (All Black)† (painted frame, Spanish)	34000.0073	120	12	2 Hoppers@3.0 gal each (2 Hoppers @ 11.4L)	136.9 lbs. (62.1 kg)	Yes	NSF ETL
ULTRA-2B (Black/Stainless)	34000.0074	100	12	2 Hoppers@3.0 gal each (2 Hoppers @ 11.4L)	136.9 lbs. (62.1 kg)	Yes	

†AFI models

Electrical: 230V models require 2-wires plus ground service rated 220-240V, single phase, 50/60Hz.
 120V models require 2-wires plus ground service, single phase, 60Hz.
 100V model requires 2-wires plus ground service, single phase, 50/60Hz.

Note: One should not use electrical extension cord to operate this machine. A dedicated circuit is recommended.

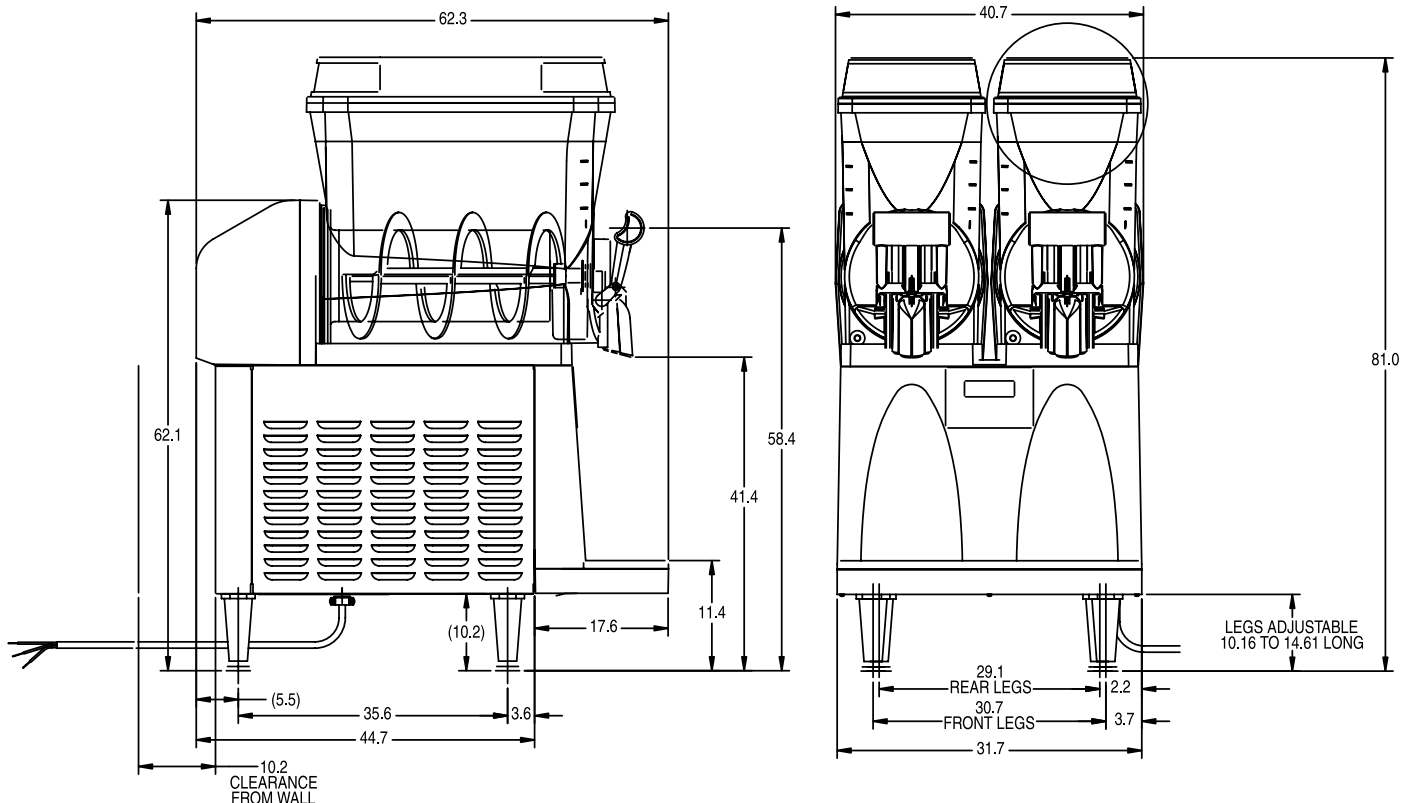

Bunn-O-Matic® Corporation - 1400 Stevenson Drive Springfield, Illinois 62703 • USA • +1-217-529-6601 • Fax +1-217-529-2827 • www.bunn.com

BUNN® practices continuous product research and improvement. We reserve the right to change specifications and product design without notice. Such revisions do not entitle the buyer to corresponding changes, improvements, additions or replacements for previously purchased equipment.

All dimensions shown in centimeters.

8/07 © Bunn-O-Matic Corporation