

SM



SM 91 - SM 96 - SM MK - SM FK

SM

An Italian myth...
...a pleasure without borders.



SM 91 - SM 96 - SM MK - SM FK

Sm

La San Marco
Made in Italy 





The range of La San Marco automatic grinders-dispensers has been realised with modern sophisticated technological solutions and innovative design concepts.

Models SM 91 and SM 96 are dosing coffee grinders with flat blades with functional characteristics that are conceived to perfectly meet different operating needs.



SM 91 - SM 96



Model SM 91

64 mm flat blades with 1350 rpm motor

Automatic version, with the possibility of programming four different times of grinding (30, 50, 80 or 120 seconds) and four different restarting settings (after 6, 12, 18 or 24 servings).



Model SM 96

84 mm flat blades with 1350 rpm motor

Automatic version, with the possibility of programming four different times of grinding (30, 50, 80 or 120 seconds) and four different restarting settings (after 6, 12, 18 or 24 servings).



Grinding capacity, quiet operation, reliability and automation are the strong points of the range.

Models SM MK and SM FK are dosing coffee grinders

with mixed conical and conical blades with functional characteristics that are conceived to perfectly adapt to

high coffee volumes.



SM MK - SM FK



Model SM MK

Mixed conical blades (two 84 mm flat blades and one conical blade)

Automatic dosing coffee grinder with the possibility of programming four different times of grinding (30, 50, 80 or 120 seconds) and four different restarting settings (after 6, 12, 18 or 24 servings).



Model SM FK

Conical blades

Automatic dosing coffee grinder with the possibility of programming four different times of grinding (30, 50, 80 or 120 seconds) and four different restarting settings (after 6, 12, 18 or 24 servings).

SM 91 - SM 96 - SM MK - SM FK



- Electronic control unit controlling grinder start and stop
- Grinding time setting at 30, 50, 80 or 120 seconds
- Coffee level restoring in the ground-coffee holder after 6, 12, 18 or 24 servings
- Ground coffee dispenser with a range of adjustments of 5 to 9 grams serving or, on request, in the larger serving configuration, from 6 to 10 grams..
- Ground-coffee holder of 250 grams capacity, with grinding stop system when maximum level is reached.
- Servings counter mounted on ground coffee holder.
- Press available in two interchangeable versions
- Hopper capacity SM 91 - SM 96 1.75 Kg
- Hopper capacity SM MK - SM FK 2.25 Kg
- Universal support for filter cup holder
- Standard colours: grey
- Metallized colours: red, sky blue, anthracite



red MT



grey



sky blue MT



anthracite MT



La gamma di macinadosatori automatici SM 91 - SM 96 - SM MK - SM FK La San Marco è stata realizzata utilizzando moderne e sofisticate soluzioni tecnologiche e innovativi concetti di design.

Capacità di macinazione, silenziosità, affidabilità, automazione costituiscono i punti di forza della gamma di macinadosatori automatici.

I modelli SM 91 e SM 96 sono macinadosatori a macine piane, con caratteristiche funzionali studiate per adattarsi perfettamente alle diverse esigenze di utilizzo.

SM 91: modello automatico con macine 64 mm

SM 96: modello automatico con macine 84 mm

I modelli SM MK (macine misto coniche) e SM FK (macine coniche) sono macinadosatori automatici a macine misto coniche (MK) e coniche (FK), con caratteristiche funzionali studiate per adattarsi perfettamente agli alti consumi di caffè.

SM MK: modello automatico con due macine piane da 84 mm ed una macina conica

SM FK: modello automatico con macine coniche

- Centralina elettronica che controlla l'avvio e l'arresto della macinatura
- Regolazione tempo di macinatura: 30, 50, 80, 120 secondi
- Regolazione impostazioni di ripartenza : 6, 12, 18, 24 prelievi
- Regolazione della dose da 5 a 9 gr. o (a richiesta) da 6 a 10 gr.
- Capienza del dosatore di 250 gr. con (nei modelli automatici) sistema di arresto automatico
- Numeratore contadosi
- Pressino in due versioni intercambiabili
- Capacità tramoggia SM 91 - SM 96 1.75 Kg
- Capacità tramoggia SM MK - SM FK 2.25 Kg
- Supporto coppa portafiltro universale
- Colori standard: grigio
- Colori metallizzati: rosso, azzurro, antracite



Das Programm der vollautomatischen Kaffeemühlen von La San Marco wurde in Anwendung modernster, hochentwickelter Technologien und nach den Grundsätzen eines innovativen Industrial Design entwickelt.

Große Mahlkapazität, geräuscharmer Betrieb, Zuverlässigkeit und Automation sind die Stärken dieser neuen Produktpalette.

Die Modelle SM 91 (Mahlwerke 64 mm) und SM 96 (Mahlwerke 84 mm) sind Dosiermühlen mit flachen Mahlwerken und haben funktionelle Merkmale, die eigens für die vollkommene Anpassung an die unterschiedlichen Verwendungszwecke entwickelt wurden:

SM 91: Automatikmodell

SM 96: Automatikmodell

Die Modelle SM MK (gemischte konische Mahlwerke) und SM FK (konische Mahlwerke) sind automatische Dosiermühlen mit gemischten konischen (MK) und konischen (FK) Mahlwerken und haben funktionelle Merkmale, die eigens für die vollkommene Anpassung an einen hohen Kaffeeverbrauch entwickelt wurden.

SM MK: Automatikmodell mit zwei flachen Mahlwerken von 84 mm und einem konischen Mahlwerk

SM FK: Automatikmodell mit konischen Mahlwerken

- Elektronisches Steuergerät, das den Start und das Anhalten der Mahlung steuert.
- Einstellung der Mahlzeit: 30, 50, 80, 120 Sekunden
- Einstellung der Neustartzeiten: 6, 12, 18, 24 Entnahmen
- Regulierung des Dosis von 5 bis 9 gr. oder (auf Anfrage) von 6 bis 10 gr.
- Fassungsvermögen des Dosierers 250 gr. mit (bei den Automatikmodellen) automatischem Stoppsystem
- Zählwerk der Dosierungen
- Kaffeestopfer in zwei austauschbaren Ausführungen
- Trichterfassungsvermögen SM 91 - SM 96 1.75 Kg
- Trichterfassungsvermögen SM MK - SM FK 2.25 Kg
- Halterung Universal-Filtertasse
- Standardfarben: grau
- metallisierte Farben: rot, blau, anthrazit



La gamme de moulins doseurs automatiques La San Marco a été réalisée en utilisant des solutions technologiques modernes et sophistiquées et un design innovant. La capacité de mouture, le fonctionnement silencieux, la fiabilité et l'automatisation représentent les points forts de la gamme.

Les modèles SM 91 (meules de 64 mm) et SM 96 (meules de 84 mm) sont des moulins-doseurs à meules plates dont les caractéristiques de fonctionnement sont étudiées pour s'adapter parfaitement aux différentes exigences d'emploi :

SM 91: modèle automatique

SM 96: modèle automatique

Les modèles SM MK (meules combinées coniques) et SM FK (meules coniques) sont des moulins-doseurs automatiques à meules combinées coniques (MK) et coniques (FK), dont les caractéristiques de fonctionnement sont étudiées pour s'adapter parfaitement aux consommations élevées de café.

SM MK: modèle automatique à deux meules plates de 84 mm et à une meule conique

SM FK: modèle automatique à meules coniques

- Centrale électronique contrôlant la mise en marche et l'arrêt de la mouture
- Réglage de la durée de mouture: 30, 50, 80, 120 secondes
- Réglage de la mise en marche: 6, 12, 18, 24 prélèvements
- Réglage du dosage de 5 à 9 g. ou (sur demande) de 6 à 10 g.
- Capacité du doseur de 250 g. Avec système d'arrêt automatique (sur les modèles automatiques)
- Compteur de doses
- Pressoir selon deux versions interchangeables
- Capacité trémie SM 91 - SM 96 1.75 Kg
- Capacité trémie SM MK - SM FK 2.25 Kg
- Support porte-filtre universel
- coloris standards: gris
- coloris métallisés: rouge, bleu, anthracite



La gama de Molinos-dosificadores automáticos La San Marco ha sido realizada utilizando soluciones tecnológicas modernas y sofisticadas y conceptos innovadores en el diseño. La capacidad de molidura, el funcionamiento silencioso, la seguridad y la automatización representan las cualidades salientes de la gama.

Los modelos SM 91 (muelas 64 mm) y SM 96 (muelas de 84 mm) son molinillos dosificadores de muelas planas, dotados de características funcionales estudiadas para adaptarse perfectamente a las distintas necesidades de uso:

SM 91: modelo automático

SM 96: modelo automático

Los modelos SM MK (muelas mixto cónicas) y SM FK (muelas cónicas) son molinillos dosificadores automáticos con muelas mixto cónicas (MK) y cónicas (FK), dotados de características funcionales estudiadas para adaptarse perfectamente a los altos consumos de café.

SM MK: modelo automático con dos muelas planas de 84 mm y una muela cónica

SM FK: modelo automático con muelas cónicas

- Central electrónica que controla el arranque y la parada del molido
- Regulación tiempo de molido: 30, 50, 80, 120 segundos
- Regulación configuraciones de arranque: 6, 12, 18, 24 extracciones
- Regulación de la dosis de 5 a 9 g. o (bajo petición) de 6 a 10 g.
- Capacidad del dosificador de 250 g. con sistema de parada automática (en los modelos automáticos)
- Numerador contador de dosis
- Apisonador en dos versiones intercambiables
- Capacidad tolva SM 91 - SM 96 1.75 Kg
- Capacidad tolva SM MK - SM FK 2.25 Kg
- Soporte copa portafiltro universal
- colores estándar: gris
- colores metalizados: rojo, azul claro, anthracita

SM 91 - SM 96 - SM MK - SM FK

Technical Data/Dati Tecnici

Modello Model Modèle Modelo	Tensione volt Voltage volt Tension volt spannung volt	Frequenza Hz Frequency Hz Fréquence Hz Frequenz Hz	Velocità motore giri/min Motor speed RPM Vitesse moteur tours/min Drehzahl motor Upm Velocidad motor giro/min	Potenza motore (w) Motor power (w) Puissance moteur (w) Motor-leistung (w) Potencia motor (w)	Tipo di macchine Type of grinders Type de broyeurs Art der mahlsteine Tipo de muelas	Capacità macinazione k/g Grinding capacity k/g Capacité de mouture k/g Mahlleistung k/g Capacidad de molidura k/g	Dimensione macine ømm Grinder size ømm Dimension broyeurs ømm Größe der mahlsteine ømm Dimension muelas ømm	Velocità macine giri/min Grinder speed RPM Vitesse broyeurs tours/min Mahl-geschwin-digkeit Upm Velocidad muelas giro/min	Emissione sonora dB A Noise level dB A Émission sonore dB A Schall-pegel dB A Emisión sonora dB A	Peso (kg) Weight (kg) Poids (kg) Gewicht (kg) Peso (kg)
SM 91	110 V-I ~ 230 V-I ~ 240 V-I ~ 230/400 V-3N ~	60 50 50 50	1350	350	Piane Flat Plats Flach Planas	8,5	64	1350	72	13,8
SM 96	110 V-I ~ 230 V-I ~ 240 V-I ~ 230/400 V-3N ~	60 50 50 50	1350	350	Piane Flat Plats Flach Planas	13	84	1350	69	13,8
SM MK	230 V-I ~ 240 V-I ~ 230/400 V-3N ~	50 50 50	700	440	Miste Mixed Mixtes Gemischt Mixtas	13	/	700	73	18,6
SM FK	230 V-I ~ 240 V-I ~ 230/400 V-3N ~	50 50 50	1350	650	Coniche Conical Coniques Konisch Cónicas	18	/	400	68	17

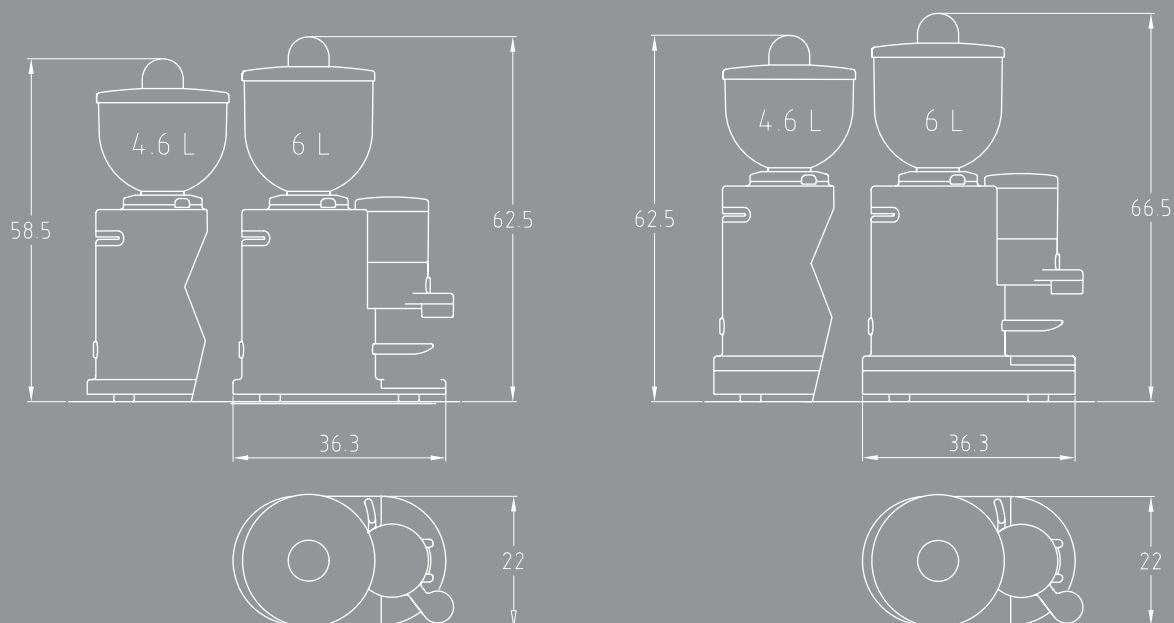

La San Marco. Wherever you go.



La San Marco spa

Via Padre e Figlio Venuti, 10 - 34072 Gradisca D'Isonzo (GO) - ITALY
Tel. (+39) 0481 967111 - Fax (+39) 0481 960166
www.lasanmarco.com info@lasanmarco.com