

ITEM#

PROJECT

DATE

Titan™ TF Server

Features



Titan TF Server

Dimensions: 23.7" H x 13.7" W x 17.1" D
(60.2cm H x 34.8cm W x 43.4cm D)

Titan TF Server

- Insulated to keep coffee hot and fresh for hours.
- Contemporary styling and wrap program for maximum merchandising.
- Large cup clearance allows for dispensing into cups, decanters and thermal carafes.
- Fast flow faucet.
- Brew-through lid.
- Integrated sight gauge assembly allows for easy cleaning.
- Innovative faucet design.
- Designed for use with Titan brewers.

For current specification sheets and other information, go to www.bunn.com.

Related Products

Titan Dual Brewer

Product No.: 39200.0002



Titan Single Brewer

Product No.: 39300.0002



TF Server Handle (orange)

Product No.: 39081.0001



Dimensions & Specifications

Model	Product #	Volts	Amps	Total Watts	Holding Capacity	Shipping Weight	Cord Attached
Titan TF Server	39400.0001	N/A	N/A	N/A	3 gallon (12 Litres)	17.5 lbs. (7.94 kg)	N/A

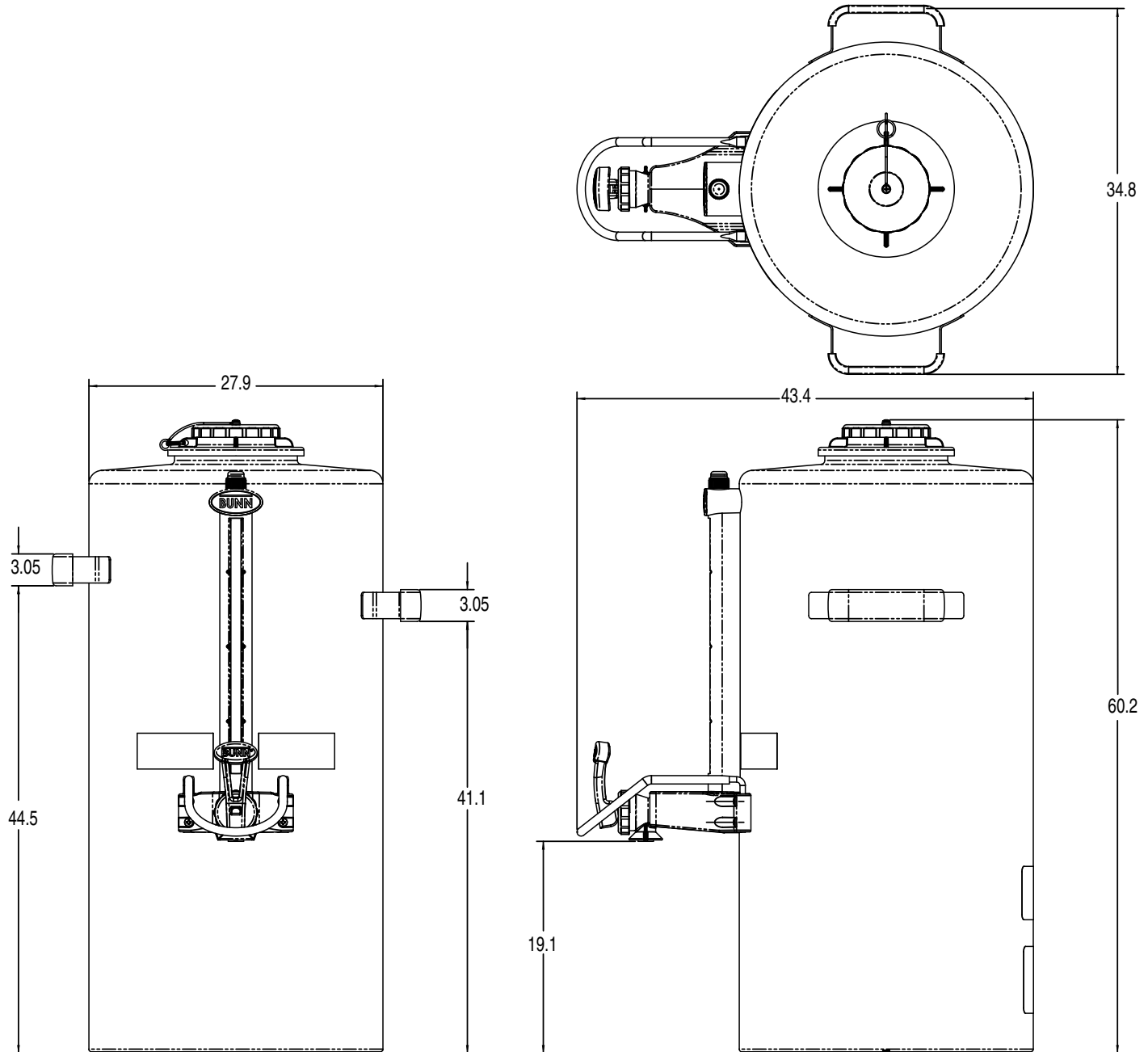

Bunn-O-Matic® Corporation - 1400 Stevenson Drive Springfield, Illinois 62703 • USA • +1-217-529-6601 • Fax +1-217-529-2827 • www.bunn.com

BUNN® practices continuous product research and improvement. We reserve the right to change specifications and product design without notice. Such revisions do not entitle the buyer to corresponding changes, improvements, additions or replacements for previously purchased equipment. All dimensions shown in centimeters.