

Thermal Carafe

Features

Thermal Carafe

- Holds 1.85 litres or 64 ounces (12 cups) of coffee or other hot beverage.
- Unbreakable stainless steel interior and exterior.
- Superior vacuum insulation keeps beverages hot for hours.
- Brew through lid allows direct brewing.
- Fits on BUNN Thermal Carafe and Twin Thermal Carafe brewers.



1.85 litre Thermal Carafe

Dimensions:
8" H x 6.4" W x 8.2" D
(20.3cm H x 16.3cm W x 21cm D)

For current specification sheets and other information, go to www.bunn.com.

Related Products

Dimensions & Specifications

Model	Product #	Capacity	Quantity	Shipping Weight	Agency
1.85 liter Thermal Carafe	36029.0001	1.85 litres (64 oz.)	single unit	1.4kg (3.0 lbs.)	☞
1.85 liter Thermal Carafe	36029.0000	1.85 litres (64 oz.)	12 units to a case	15.4 kg (34 lbs.)	☞
1.85 liter Thermal Carafe*	36252.0001	1.85 litres (64 oz.)	single unit	1.4kg (3.0 lbs.)	☞
1.85 liter Thermal Carafe*	36252.0000	1.85 litres (64 oz.)	12 units to a case	15.4 kg (34 lbs.)	☞

Note: *Orange lid (for decaf).

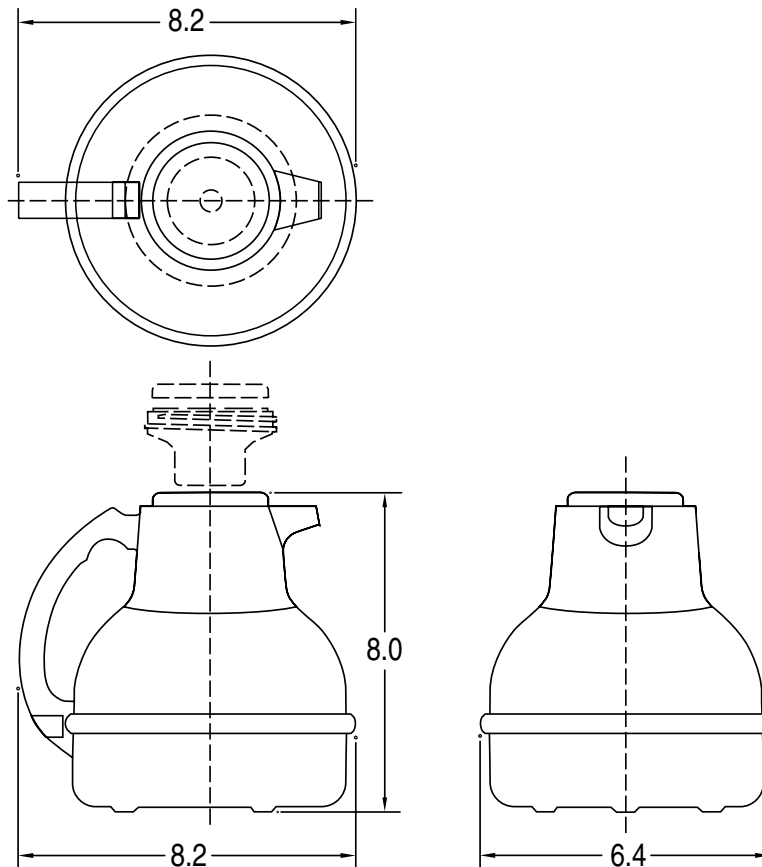

BUNN Corporation - 1400 Stevenson Drive Springfield, Illinois 62703 • USA • +1-217-529-6601 • Fax +1-217-529-2827 • www.bunn.com

BUNN® practices continuous product research and improvement. We reserve the right to change specifications and product design without notice. Such revisions do not entitle the buyer to corresponding changes, improvements, additions or replacements for previously purchased equipment.

All dimensions shown in centimeters. Bunn Corporation owns all copyrights relating to materials in this publication. Please contact Bunn Corporation to request permission to reproduce any portion of this publication.