

## Coffee Decanters and Warmers



*Easy Pour<sup>®</sup> Decanters*

### Features

#### Easy Pour<sup>®</sup> Coffee Decanters

- Container and handle core are molded as sturdy, extra-strength, one-piece construction for longest life.
- Clear, high-impact-resistant material.
- Base is high quality stainless steel.
- Drip-proof, fast-pour lip—an exclusive BUNN design to assure convenient serving. Fast, clean pouring from front or either side.
- Easy Pour<sup>®</sup> decanters can be private labeled. Please contact your BUNN sales representative for more information.

### More Quality Decanters



*Glass Decanters*



*Stainless Steel Decanters*

For current specification sheets and other information, go to [www.bunn.com](http://www.bunn.com).

### Related Products

#### WX2-warmer

Two position warmer



#### WS2B-warmer

Two position warmer



## Dimensions & Specifications

Model	Product # Black Handle	Product # Orange Handle	Shipping Weight
Easy Pour®, 64 oz., case of 1	06100.0101	06101.0101	1 lb. (0.5 kg)
Easy Pour®, 64 oz., case of 2	06100.0102	06101.0102	2 lbs. (0.9 kg)
Easy Pour®, 64 oz., case of 3	06100.0103	06101.0103	3 lbs. (1.4 kg)
Easy Pour®, 64 oz., case of 6	06100.0106	06101.0106	6 lbs. (2.7 kg)
Easy Pour®, 64 oz., case of 12	06100.0112	06101.0112	12 lbs. (5.5 kg)
Easy Pour®, 64 oz., case of 24	06100.0124	06101.0124	23 lbs. (10.4 kg)
Decanter, glass 64 oz., case of 1	06078.0001	06088.0001	1 lb. (0.5 kg)
Decanter, glass 64 oz., case of 2	06078.0002	06088.0002	2.5 lbs. (1.1 kg)
Decanter, glass 64 oz., case of 3	06078.0003	06088.0003	4.5 lbs. (2.1 kg)
Decanter, glass 64 oz., case of 6	06078.0006	06088.0006	7.5 lbs. (3.4 kg)
Decanter, glass 64 oz., case of 12	06078.0012	06088.0012	15 lbs. (6.8 kg)
Decanter, glass 64 oz., case of 24	06078.0024	06088.0024	26 lbs. (11.8 kg)
Decanter, stainless steel, 64 oz.	06026.0000	06041.0000	1.5 lb. (0.7 kg)

Model	Product #	Volts	Amps	Total Watts	Shipping Weight	Cord Attached	Agency
WX2A	06310.0006	230	1	200	4 lbs. (1.8 kg)	No	
WS2B	12882.0002	100	2	200	7 lbs. (3.2 kg)	No	CE

Electrical: 230 volt model requires 2-wires plus ground service rated 220-240V, single phase, 50/60 Hz.  
100 volt model requires 2-wires plus ground, single phase, 50 Hz.

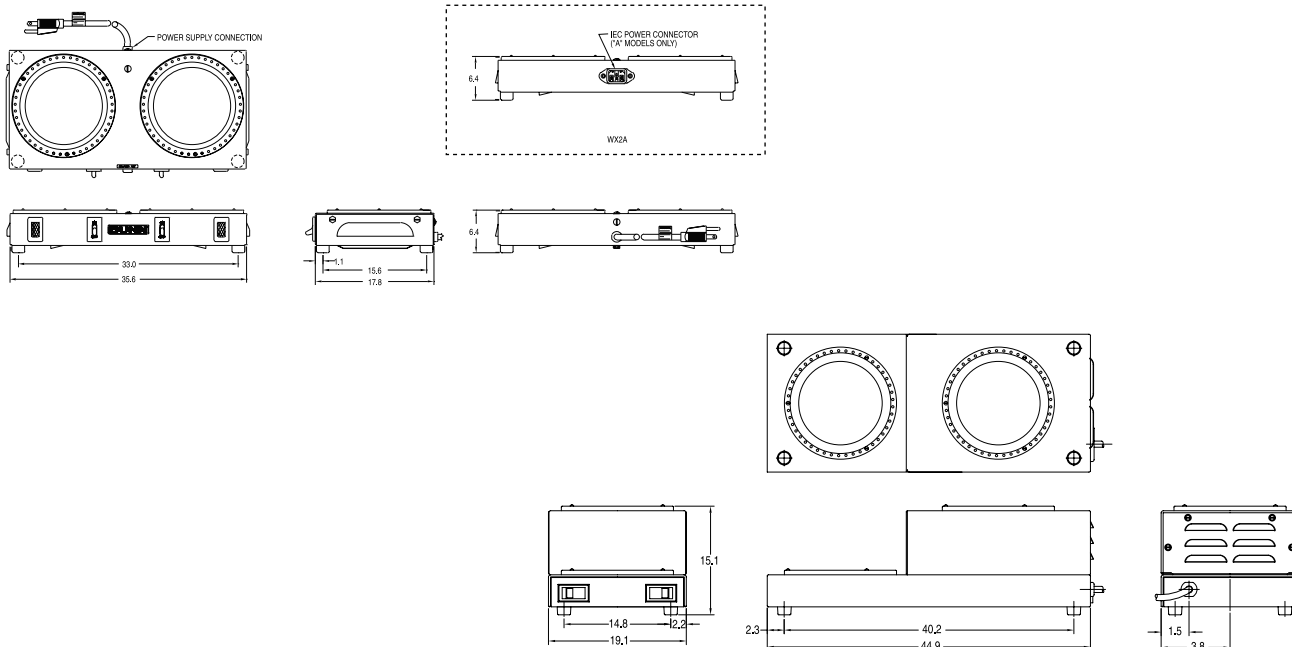

Bunn-O-Matic® Corporation - 1400 Stevenson Drive Springfield, Illinois 62703 • USA • +1-217-529-6601 • Fax +1-217-529-2827 • www.bunn.com

BUNN® practices continuous product research and improvement. We reserve the right to change specifications and product design without notice. Such revisions do not entitle the buyer to corresponding changes, improvements, additions or replacements for previously purchased equipment.

**All dimensions shown in centimeters.** Bunn-O-Matic Corporation owns all copyrights relating to materials in this publication. Please contact BUNN to request permission to reproduce any portion of this publication.